



ACT Series

CEILING TILE HEATER



ACT Series

CEILING TILE HEATER

Introduction

Airbloc ACT Series is an electric or LPHW heater that directs a down-flow of warm air from overhead, delivering immediate heat where required and rapidly creating a Comfortable environment for staff and customers.

The ACT Series is designed to complement the Airbloc air curtain range to provide a cost-effective heating solution.

ACT Series Applications

- Hospitals
- Restaurants
- Retail outlets
- Schools
- Showrooms
- Stockrooms



Features & Benefits

- Maximum mounting heights 2.5m to 3m
- Compact dimensions to fit shallow ceiling voids
- Immediate warmth
- Quiet operation
- Good aesthetic appearance
- Low maintenance

Model Range

- Surface mounted or recessed to replace a standard 1.2m or two 600mm ceiling tiles.
- Available with two heating capacities of 9kW and 12kW.
- Available in a white finish (RAL 9010) to ensure the visual integrity of the interior is retained.



Perfect complement for Airbloc energy saving air curtains

A new energy saving control unit that reduces both power consumption and energy costs by up to 50%, SmartElec² is the perfect complement for Airbloc energy saving air curtains.

- Simple installation - wiring via a plug and play cable and connectors are direct to the controller, no intermediary terminal blocks are required
- Easy programming - users merely select whether they require the heat on or off, the required fan setting (1, 2 or 3 speed), and the outlet temperature setting
- Energy saving - intelligent controller monitors set temperatures to ensure that once reached the unit merely modulates to maintain temperature
- Reduced payback period on investment thanks to the significant energy savings generated



Dimensions

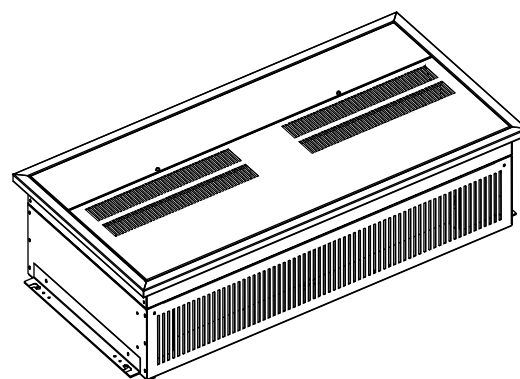
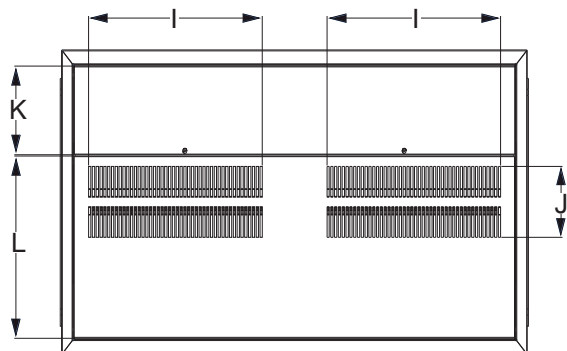
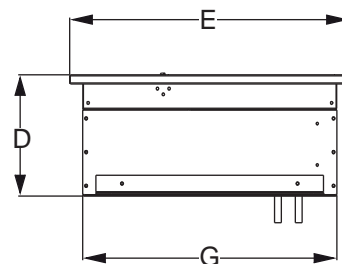
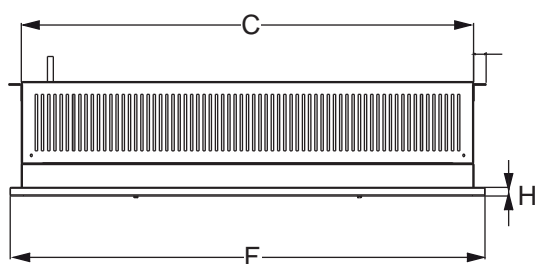
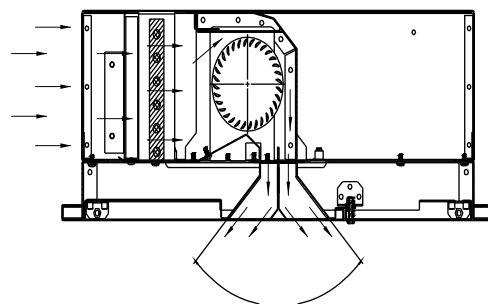
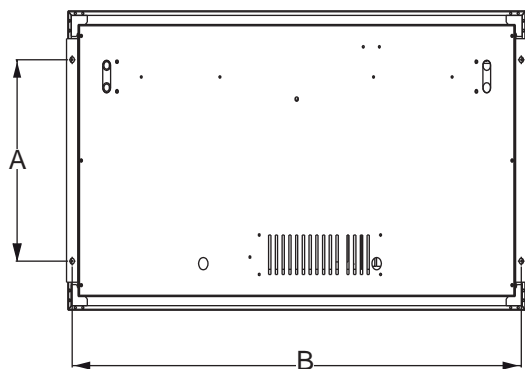

DIMENSIONS

Model			ACT120E9R ACT120E9S	ACT120E12R ACT120E12S	ACT120W9R ACT120W9S	ACT120W12R ACT120W12S
A	Suspension point	mm	1199	1199	1199	1199
B	Suspension point	mm	408	408	408	408
C	Unit length	mm	1165	1165	1165	1165
D	Unit height	mm	223	223	223	223
E	Unit width	mm	550	550	550	550
F	Grille length	mm	1223	1223	1223	1223
G	Grille width	mm	606	606	606	606
H		mm	17	17	17	17
I		mm	456	456	456	456
J		mm	141	141	141	141
K	Electrical access	mm	177	177	177	177
L	Rotor/motor access	mm	363	363	363	363

SPECIFICATION

		Electric*		LPHW*	
Model		ACT120E9R ACT120E9S	ACT120E12R ACT120E12S	ACT120W9R ACT120W9S	ACT120W12R ACT120W12S
Maximum mounting height	mm	3000	3000	3000	3000
Maximum air volume	m ³ /h	921	921	921	921
Maximum velocity	m/s	3.8	3.8	3.8	3.8
Maximum heating capacity	kW	9	12	9	12
Approximate weight	kg	33	33	33	33
Motor power	W	60	60	60	60
Electrical supply		415 volt 3 phase 50Hz		230 volt 1 phase 50Hz	
Total electrical load (per phase)	amps	14.2	18.2	2.5	2.5

*For all models please suffix with SM if you require a SmartElec² energy saving controller

 AnbiRad Group brand



AmbiRad Limited Fens Pool Avenue
Brierley Hill West Midlands DY5 1QA
United Kingdom



Telephone: 01384 489700
Facsimile: 01384 489707
Email: marketing@airbloc.co.uk
Website: www.airbloc.co.uk



ENERGY SAVING AIR CURTAINS

Airbloc is a registered trademark of AmbiRad Limited. Because of continuous product innovation, Ambirad reserves the right to change product specification without due notice.